

M O D E L S

OS6.3Si

OS5.3Si



Stereo Input Indoor/Outdoor Loudspeaker



# CONGRATULATIONS

Thank you for choosing a Niles OS Indoor/Outdoor Loudspeaker. With proper installation and operation, you'll enjoy years of trouble-free use.

Niles manufactures the industry's most complete line of custom installation components and accessories for audio/video systems. To learn more about Niles products visit our website: [www.nilesaudio.com](http://www.nilesaudio.com) or call us at **800-BUY-HIFI** (800-289-4434).

## TABLE OF CONTENTS

INTRODUCTION	2
FEATURES & BENEFITS	3
PARTS GUIDE	5
INSTALLATION CONSIDERATIONS	7
PAINTING THE OS SERIES LOUDSPEAKER	12
INSTALLATION	15
OPERATION	18
SPECIFICATIONS	19
WARRANTY REGISTRATION CARD	21
LIMITED WARRANTY	22

## INTRODUCTION

Niles once again raises the bar. With our first OS Indoor/Outdoor models we revealed a radical new understanding of loudspeaker capabilities. Niles original OS Indoor/Outdoor loudspeakers are constantly praised for their ability to deliver exemplary reliability and outstanding sound quality. These attributes have made Niles OS Indoor/Outdoor loudspeakers the best selling loudspeakers in their class.

The goal of our new OS Indoor/Outdoor line-up is to raise this bar with refined appearance and superior sonic performance. Once again establishing a benchmark by which all others are judged. The new Niles OS Indoor/Outdoor loudspeakers owe much of their performance and sound quality advantage to design elements pioneered in the award-winning Niles DS Directed Soundfield™ loudspeakers. Their engineering advances come from our integrated approach to driver and cabinet design. By integrating the woofer basket into the baffle of the cabinet we are able to increase the woofer cone-area to cabinet-width ratio. Thus enabling OS Indoor/Outdoor loudspeakers to provide levels of bass performance that substantially exceed their physical size. However, deeper and more powerful bass isn't the only refinement in the new OS Indoor/Outdoor line-up. A new and modern style enables OS Indoor/Outdoor loudspeakers to blend seamlessly with the architectural elements both indoors and out. After the installation is complete, you will be astonished by the experience of hearing such clean and powerful sound coming from such an elegant appearing loudspeaker.



## FEATURES & BENEFITS

### **Stereo Input “Si” Design**

Plays both left and right channels to provide broad sound coverage and a stereo effect from a single loudspeaker

### **Patent Pending Integrated Woofer/Baffle Assembly**

Increases the woofer cone-area to cabinet-width ratio for enhanced bass output

### **Mica-Filled Polypropylene Woofer Cone**

Reduces breakup and lowers distortion

### **Butyl Rubber Woofer Cone Surround**

Damps resonance and provides exceptional durability

### **Dual Voice Coil Woofer**

Delivers both left and right channels from one loudspeaker

### **Dual UltraSilk™ Dome Tweeters**

1" fluid-cooled tweeters provides ultra-wide dispersion for clear, detailed and extended high-frequencies

### **Stereo Imaging Tweeter Array**

Directs the high frequency sounds from both the right and left channels from one loudspeaker

### **Weatherproof Engineering**

Enables OS loudspeakers to handle extreme hot, cold and moist environments, exceeding the military's strict anti-corrosion specification MIL-STD-883D

### **Advanced Material Science**

Elevates appearance and longevity of the cabinet and grille, plus enhances the performance of the woofers, tweeters and crossovers

**Architectural Friendly Design**

Delivers stellar acoustical performance yet tucks discretely away into corners and under eaves

**Low Diffraction Grille and Front Baffle**

Ensures that the sound waves emanating from the woofer and tweeter are not reflected by the surrounding parts of the loudspeaker for precise imaging and acoustical accuracy

**Rigid, Acoustically Inert Cabinet**

Prevents transmission of unwanted vibrations for clean and dynamic bass response

**All-Weather Versatility**

Reduces installation limitations to provide great sound from the beaches of Miami to the harsh winters of Minneapolis

**Home Theater Applicability**

Enables OS loudspeakers to be used as left, center, right, or surround speakers in home theater systems

**Integrated Mounting Bracket and Shelf Stand**

Provide a variety of secure, quick and easy mounting solutions

**Tapered Shape**

Facilitates mounting in corners and under eaves

**Inverted Gold Plated 5-Way Binding Posts**

Repel moisture and ensure positive connections in virtually any conditions over long periods of time

## PARTS GUIDE

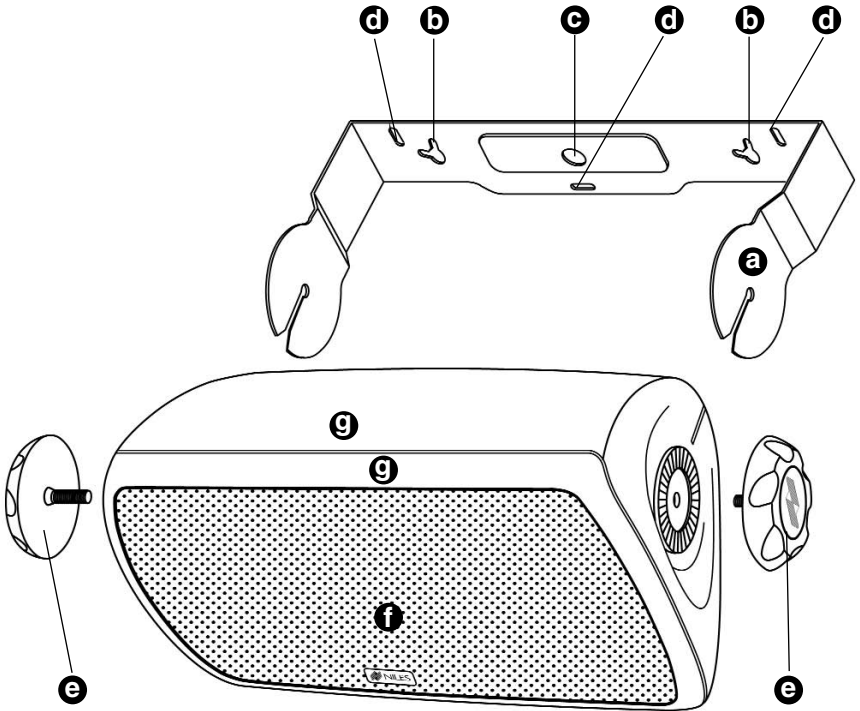

**Figure 1** OS-5.3Si and OS-6.3Si Parts Guide

- |                 |                                          |
|-----------------|------------------------------------------|
| a. Bracket      | f. Grille                                |
| b. Nail Hole    | g. Cabinet                               |
| c. Wire Hole    | h. Binding Posts                         |
| d. Screw Hole   | i. Threaded Insert (1/4"-20 Thread size) |
| e. Bracket Knob |                                          |

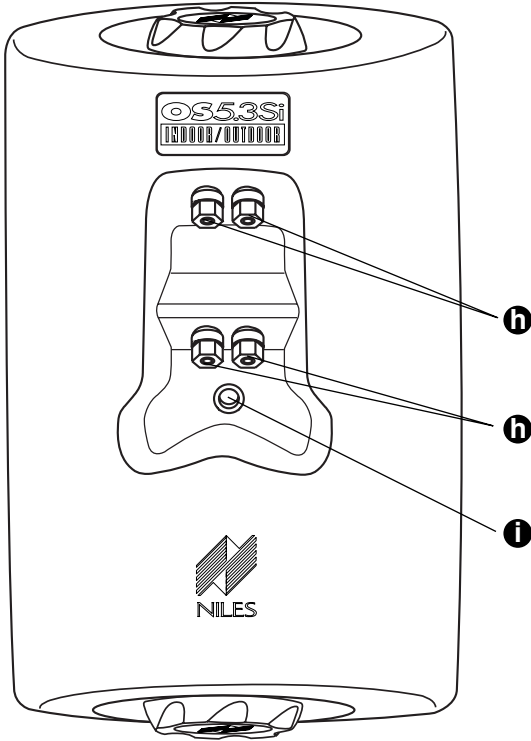

## INSTALLATION CONSIDERATIONS

### Tools and Materials Required

- A wire stripper
- A pencil
- A level (optional)
- Three screws or bolts suitable for the mounting surface
- The proper screwdriver for your mounting hardware
- A drill bit of the right size and type
- An electric drill

### Wiring

The OS loudspeaker connects to your receiver or amplifier using 2x2-conductor loudspeaker wire (**See Figure 2**). For most applications, we recommend using 16 or 18 gauge wire. For wiring runs longer than 80 feet, we recommend 14 gauge wire. The binding posts on the OS loudspeaker will accommodate up to 12 gauge wire directly. Larger sizes can be accommodated using spade, banana, or pin connectors.

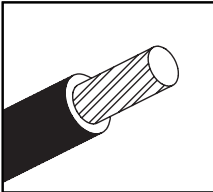

### TECH TIP

**Wire size is expressed by its AWG (American Wire Gauge) number. The lower the number, the larger the wire, i.e. twelve AWG is physically larger than fourteen AWG.**

When you run wire inside walls, outdoors or in marine installations, special jacketing or conduit is required for a trouble-free installation and conformation to the local and national building codes. If you are not sure of the correct wire jacket or type of conduit to use, consult a professional audio/video installer, building contractor, or the local building and inspection department.



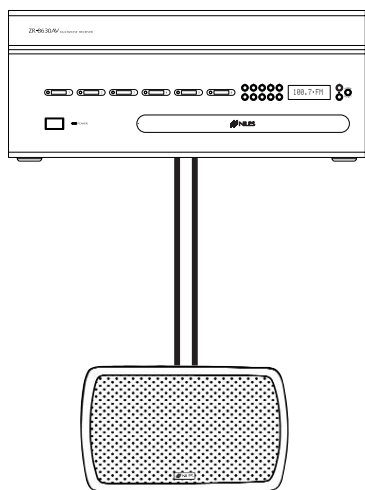

**Figure 2**  
Wiring directly from a receiver  
or amplifier

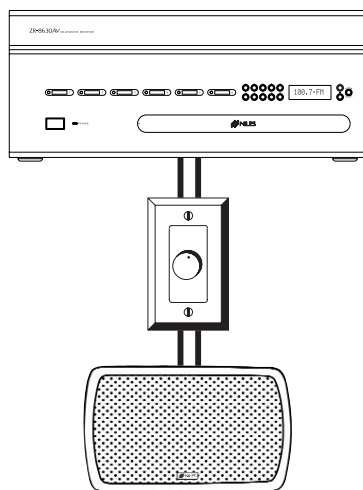

**Figure 3**  
Incorporating a volume control

### Incorporating a Volume Control

It's possible to control the volume of the sound at the loudspeaker location. Plan to wire the system so that each loudspeaker has its own volume control. Niles makes a wide range of indoor and outdoor volume controls. Consult your local Niles dealer for more information. Volume controls are connected in line with the speaker, so you must connect the wire from the amplifier to the volume control and then from the volume control to the loudspeaker (See Figure 3).

### Recommended Amplifier Power

For the OS 5.3Si loudspeaker, we recommend an amplifier with a power rating of five (5) to one hundred (100) watts per channel for optimum performance. For the OS 6.3Si loudspeaker, we recommend an amplifier with a power rating of five (5) to one hundred twenty five (125) watts per channel for optimum performance. Ironically, most speakers are not damaged by large amplifiers but by small amplifiers. If you are playing at high volume, a small amplifier will run out of power very quickly. When an amplifier runs out of power it creates damaging "clipping" distortion. A large amplifier will play at the same volume without distorting. See the section "Operation" for more information about clipping distortion.

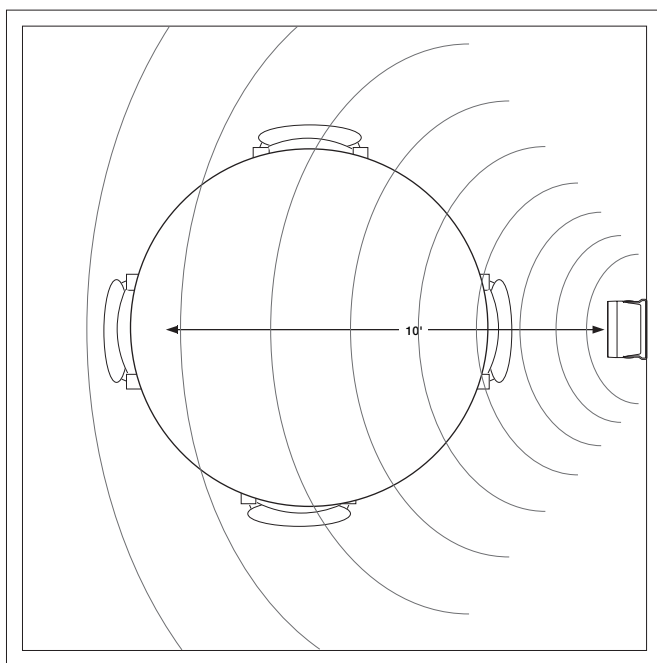

**Figure 4**  
Illustration depicts the optimum placement zone for a listening distance of ten feet.

### Placing the OS Loudspeaker for the Best Sound Quality

Traditionally, when using a pair of stereo loudspeakers, the listener will be positioned directly between the left and right loudspeakers to achieve optimum stereo sound. However, in some applications this is not possible, especially when a large area of coverage is required. It was for these types of applications that the OS “Si” loudspeaker was created. With its ultra wide dispersion pattern, a single OS “Si” loudspeaker is able to project quality stereo sound over a larger area. No matter where you are—you are always in the sweet spot. (See **Figure 4**).

Make sure that you are not blocking or reflecting the sound off of furniture or other objects. You should have a direct line of sight with the front of the loudspeaker.

You can control the loudspeakers bass output by placement. This is called the boundary effect. You will get more bass response by mounting the OS loudspeaker directly to a wall or other flat surface (any boundary close to the loudspeaker will reinforce the bass frequencies). You can increase the bass output even more by mounting the OS loudspeaker in a corner or under an eave (**See Figure 5**) This type of placement gives the loudspeaker two boundaries, both reinforcing the bass sounds. Of course, if you wish to hear less bass, try moving the loudspeaker away from the boundary (**See Figure 6**).

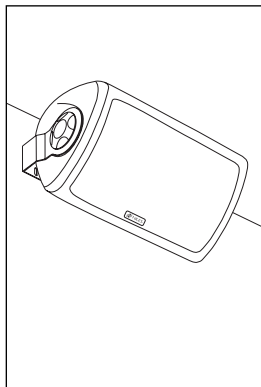

**Figure 5**  
Placement for more bass output

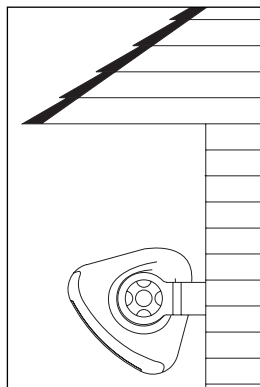
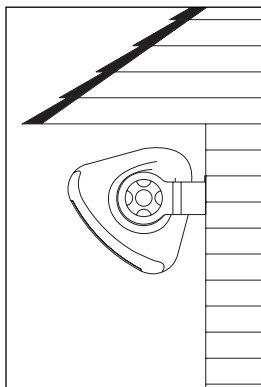
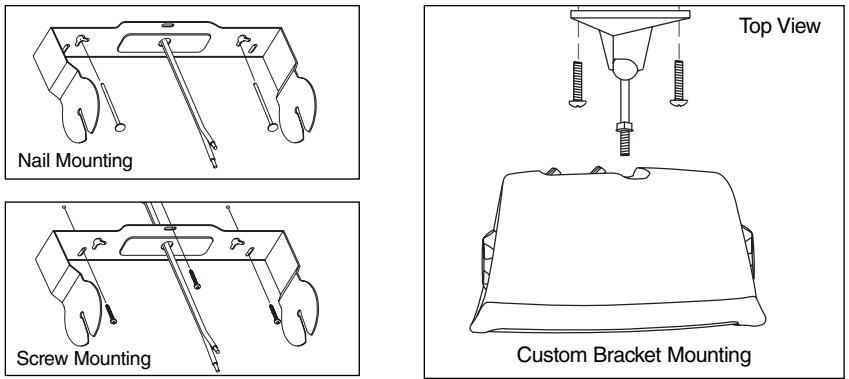

**Figure 6**  
Placement for less bass output

### Mounting Methods

The OS loudspeaker should be mounted horizontally. The bracket knobs will keep the loudspeaker angled correctly in any position once they are tightened. You can choose from three mounting methods to attach the OS loudspeaker to the wall, ceiling, or other mounting surface.

1. If the loudspeaker is never going to be exposed to sudden accidental impacts, wind, waves or earthquakes you can simply hang it on a nail using the nail hole(s) on the bracket (**See Figure 7**).
2. The safest and most secure way to mount the loudspeaker is by screwing it to the mounting surface using your own hardware (suitable for the surface you are mounting to) and the bracket supplied with the loudspeaker (**See Figure 7**).



**Figure 7** The OS loudspeaker can be mounted three ways.

3. There is a threaded brass insert (1/4" – 20) on the back of the OS loudspeaker for attaching a custom bracket (See **Figure 7**). This allows you to position the loudspeaker at unusual angles or varying distances from the mounting surface.

**Safety First!**

Be careful to use hardware that is designed for the surface you are mounting to. The OS 5.3Si loudspeaker (including bracket) weighs 9 pounds. The OS 6.3Si loudspeaker (including bracket) weighs 11 pounds. If you are not sure of a safe way to mount the loudspeakers, consult a professional installer or a building contractor.

You will maximize the useful life of the loudspeaker, by placing the loudspeaker so that it receives less exposure to the elements. Look for the best overall compromise between sound quality, convenience, and exposure. Do not compromise safety.

## PAINTING THE LOUDSPEAKER

The enclosure, the brackets, and the grilles of the OS loudspeaker can all be painted to match the surroundings. Because we want you to preserve the acoustic qualities of the grille, please paint the grille according to the grille painting instructions. Make sure you pick a paint that is appropriate for the mounting location. There are interior and exterior varieties, and even paint for marine uses. If you are not sure what paint to use, consult a paint store professional or a painter.

### Tools Required

- A spray can of primer paint
- The correct paint for the environment/use (oil or water based paint is fine)
- A paint brush or applicator if the paint is not in a spray can.
- A paper clip or an awl (for removing the grille)
- Masking tape
- 2 paint masks (supplied)
- A damp cloth and a dry cloth

### Preparing to Paint

1. Separate the parts of the speaker. You should remove the brackets and the bracket knobs. Remove the grille by hooking it with a bent paper clip or the tip of an awl and pulling it away from the cabinet (**See Figure 8**).

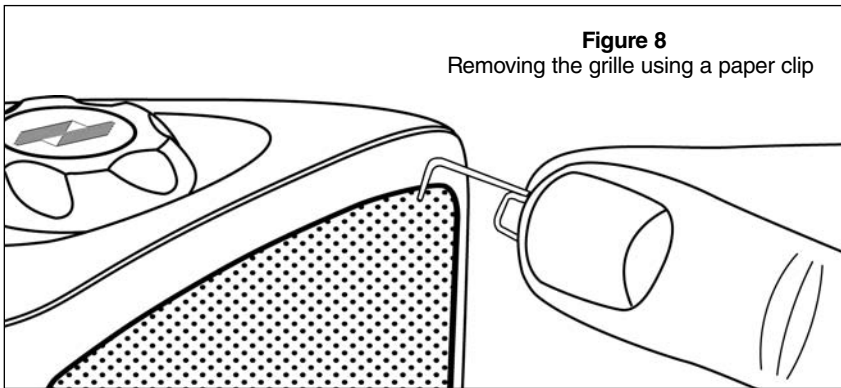

**Figure 8**  
Removing the grille using a paper clip

2. Wipe off the other sides of the cabinet, the bracket, bracket knobs, and grille with a damp cloth. Do not touch or rub the loudspeakers on the front baffle. Make sure everything is dry before masking.
3. Mask off the binding posts and the brass threaded inserts on the back panel with masking tape.
4. Mask off the threaded inserts on the top and bottom with masking tape.
5. Protect the front of the loudspeaker by inserting the supplied paint mask in place of the grille.

### **Painting the Cabinet, Bracket Knobs and Bracket**

1. Apply two thin coats of a sandable spray primer to the cabinet and knobs. The bracket doesn't require a coat of primer.
2. Allow the primer to dry completely.
3. Apply the finish color.
4. Allow the paint to dry completely.
5. Carefully remove the masking material.
6. Do not reattach the loudspeaker to the bracket until the bracket is mounted. Try to keep all handling of the freshly painted parts to a minimum.

### **Painting the Grille**

The grille is important to the sound of the OS loudspeaker. Do not fill the holes of the grille with paint. The grille is constructed of aluminum with a perfectly even powder coat overall. This powder coat is an ideal primer.

If you are using a spray paint, use two thin coats without any primer. If you are using a compressor and a spray gun, use the finest, most diffuse setting. Practice on paper if you are not experienced in painting with spray paint.

If you are using an applicator or brush and a can of paint, thin the paint first. Thick paint will tend to clog the grille holes. To ensure a uniform appearance, paint the front and back of the grille.

### **Replacing the Grille**

Carefully fit the grille into its recess so that it is barely in place. Starting with one corner, go around the speaker, pushing the grille in a little bit each time. You should be gentle, the aluminum grille can be bent easily out of shape. You will feel a positive “snap” when it is in place.

## INSTALLATION

### Mounting the Bracket (if attaching the loudspeaker to a wall, ceiling, beam or other solid structure)

1. Loosen the bracket knobs and remove the bracket from the loudspeaker.
2. Hold the bracket up to the mounting surface. The loudspeaker can be mounted either horizontally or vertically. Hold the bracket so that the loudspeaker wire fits through the large, circular wire hole in the center of the bracket. Align the bracket to be square with the surroundings (use a level for accuracy).
3. Mark the locations of the three oval-shaped screw holes (See Figure 9). Be sure to use all of the holes.
4. Drill pilot holes into the mounting surface.

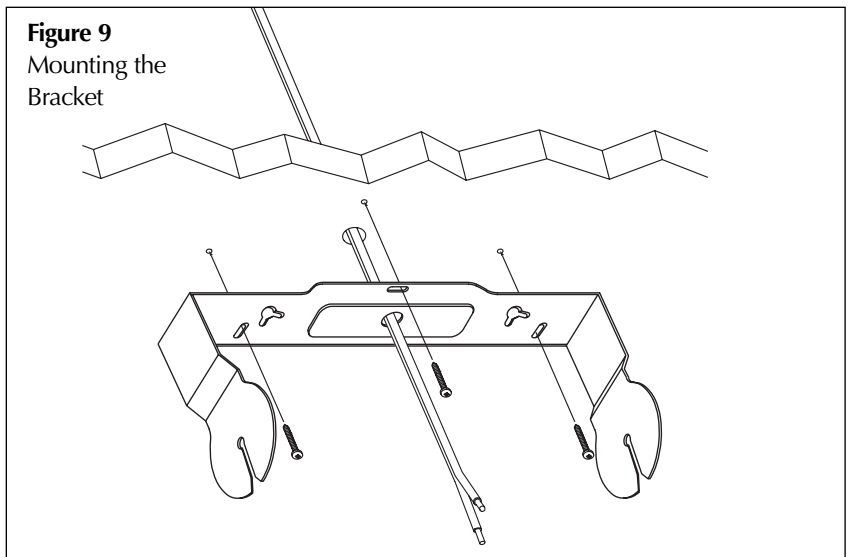

5. Pull the loudspeaker wire through the wire hole in the center of the mounting bracket. Align the bracket so that the holes all line up.
6. Use your hardware to attach the bracket to the mounting surface.



### Connecting the Loudspeaker

1. Separate the two conductors of each loudspeaker wire so that at least two inches of each conductor are free.
2. Strip one half inch of insulation from the end of each conductor of the loudspeaker wires.
3. If you have any connectors (gold pins or bananas) which you prefer to use, affix them to the stripped wire ends now. Only gold plated connectors should be used outside as they will not tarnish or corrode.
4. If using the bracket to attach to a solid surface, slide the loudspeaker onto the bracket. Do not tighten the knobs completely. Angle the loudspeaker so that the rear terminals are accessible.
5. Connect one stripped wire end to the black and one to the red terminal (repeat this for the other channel). Pay attention to the markings on the wire. Each channel must be connected to the amplifier in the same way.
6. If required, attach the safety cable to the loudspeaker enclosure. See *Safety First* section for details.
7. Verify that the loudspeaker is in-phase as described in the *Loudspeaker Phase* section.
8. Angle the loudspeaker for the best sound possible.

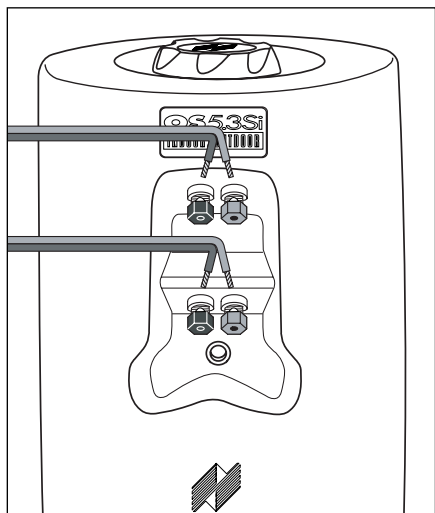

**Figure 10**  
Loudspeaker Wire  
Connection

9. Tighten the bracket knobs using only your hands. Use of any power tools may over-tighten the knob, and strip the threads of the insert.
10. Check that the entire installation is safe and secure.

### **Loudspeaker Phase**

Loudspeaker wire has two conductors. One conductor is attached to the negative (-) terminals and one conductor is attached to the positive (+) terminals of both your loudspeaker and your amplifier. Usually, the wire is marked for your convenience. There are different ways to mark the wire; a stripe on one wire, a ribbed area of one conductor you can only feel, different colors of metal wire on each conductor, or there might be a fabric strand or string wound into one of the conductors. Of course, there are some wires which appear completely identical. Be careful to avoid mistakes. If you do, the woofer of the OS loudspeaker will not be playing loudly. If you do not hear any or very little "bass" coming from the loudspeaker try this simple test:

1. Play some music with the amplifier or radio set to Mono.
2. Listen to the richness of the bass and the loudness of the sound.
3. Turn off the amplifier and reverse the connections on one loudspeaker terminal only.
4. Repeat the listening test with the same setting of the volume control.
5. If the sound is louder in step 4 than step 2 leave the terminals connected the way they are. If not, put the connections back the way they were in step 1.

## OPERATION

### **Listening at Higher Volumes**

Outdoors there are no walls to reflect and contain the sound. It requires more power to achieve a reasonable volume of sound outside than it does when you are indoors. You also frequently find yourself very far from the loudspeaker. It is possible to turn the volume so high that the amplifier runs out of power. This creates “clipping” distortion.

Clipping distortion makes treble sound very harsh and unmusical. When you hear harsh sounding treble from any good loudspeaker indoors or outdoors, turn the volume down immediately! Those harsh sounds are masking some much more powerful ultra-high-frequency sound spikes which will quickly damage any fine loudspeaker.

### **Cleaning**

You can clean the OS loudspeaker with a dampened soft cloth or paper towel. If the loudspeaker is mounted high up on a wall or ceiling, use a broom to gently brush it off. Hosing off the loudspeaker is not recommended, as the tweeter is a precise mechanism which might be damaged by a high pressure stream of water.

## SPECIFICATIONS

### OS6.3Si Loudspeaker

#### Recommended Amplifier Power

5W – 125W per channel

#### Nominal Impedance

8 ohms per channel, wired in stereo or 4 ohms with both channels wired together

#### Frequency Response

75Hz – 21kHz +/-3dB

#### Sensitivity

90dB for 2.83V pink noise

#### Wiring Requirements

Sixteen to eighteen gauge 2-conductor (unshielded or shielded) wire for runs up to eighty feet. Fourteen gauge 2-conductor (unshielded or shielded) wire for runs up to two hundred feet.

#### Dimensions (Loudspeaker with U-Bracket)

13-5/16" high x 8-3/16" wide  
x 9-3/16" deep

#### Weight (Loudspeaker and Bracket)

11 lbs.

#### Warranty

2 year limited

### OS5.3Si Loudspeaker

#### Recommended Amplifier Power

5W – 100W per channel

#### Nominal Impedance

8 ohms per channel, wired in stereo or 4 ohms with both channels wired together

#### Frequency Response

85Hz – 21kHz +/-3dB

#### Sensitivity

90dB for 2.83V pink noise

#### Wiring Requirements

Sixteen to eighteen gauge 2-conductor (unshielded or shielded) wire for runs up to eighty feet. Fourteen gauge 2-conductor (unshielded or shielded) wire for runs up to two hundred feet.

#### Dimensions (Loudspeaker with U-Bracket)

12" high x 7-7/16" wide  
x 7-3/4" deep

#### Weight (Loudspeaker and Bracket)

9 lbs.

#### Warranty

2 year limited

PLEASE FILL OUT THE  
WARRANTY REGISTRATION  
CARD ON THE REVERSE SIDE,  
DETACH, AND MAIL TO:

**Niles Audio Corporation**  
**Warranty Registration Dept.**  
**P.O. Box 160818**  
**Miami, Florida 33116-0818**



NILES®

DETACH HERE

# WARRANTY REGISTRATION CARD

Model Purchased \_\_\_\_\_

Serial Number \_\_\_\_\_

Date Purchased (month/day/year) \_\_\_\_\_

Dealer Name and Location \_\_\_\_\_

Dr.     Miss     Mr.     Mrs.     Ms.

Name \_\_\_\_\_

Address \_\_\_\_\_

City \_\_\_\_\_ State \_\_\_\_\_ Zip \_\_\_\_\_

Telephone ( \_\_\_\_\_ ) \_\_\_\_\_

**Please take a moment to fill out our warranty registration card. The information helps us to get to know you better and develop the products you want**

**Age:**

- Under 25
- 25-34
- 35-44
- 45-54
- 55 & over

**Income:**

- Under \$24,999
- \$25,000-\$34,999
- \$35,000-\$44,999
- \$45,000-\$59,999
- \$60,000-\$74,999
- \$75,000-\$99,999
- Over \$99,999

**Occupation:**

- Arts/Entertainment
- Business Owner
- Engineer
- Finance/Accounting
- General Office
- Management
- Professional
- Sales/Marketing
- Student
- Tradesperson

**Musical tastes:**

(Please check all that apply)

- Alternative
- Classical
- Country
- Jazz
- New Age
- Popular
- R&B
- Rock
- Other \_\_\_\_\_

**How did you hear about Niles?**

- Architect/Developer
- Custom Installer
- Direct Mail
- Friend/Family
- In-Store Display
- Interior Designer
- Magazine Ad
- Mail-Order Catalog
- Newspaper Ad
- Product Brochure
- Product Review
- Retail Salesperson

**What magazines do you read?**

1. \_\_\_\_\_
2. \_\_\_\_\_
3. \_\_\_\_\_

**Who will install the product?**

- Custom Installer
- Electrician
- Friend
- Myself

**Which factor(s) influenced the purchase of your Niles product?**

(Please check all that apply)

- Ease of Use
- Price/Value
- Product Features
- Quality/Durability
- Reputation
- Style/Appearance
- Warranty

**Do you . . . ?**

- Own a House. If yes, how many square feet? \_\_\_\_\_
- Own a Town House/Condominium/Co-op
- Rent an Apartment
- Rent a House

**Are you interested in receiving literature on other Niles products?**

- Yes     No

**Are there products/capabilities that you would like to see introduced?**

\_\_\_\_\_

\_\_\_\_\_

\_\_\_\_\_

\_\_\_\_\_

\_\_\_\_\_

## 2 YEAR LIMITED WARRANTY

Niles Audio Corporation ("NILES") warrants its outdoor loudspeaker products to the original purchaser to be free of manufacturing defects in material and workmanship for a period of two years from date of purchase.

This Warranty is subject to the following additional conditions and limitations. The Warranty is void and inapplicable if NILES deems that the product has been used or handled other than in accordance with the instructions provided by the manufacturer, including but not limited to damage caused by accident, mishandling, improper installation, abuse, negligence, or normal wear and tear, or any defect caused by repair to the product by anyone other than NILES or an authorized NILES dealer.

To obtain warranty service, take the unit to the nearest authorized NILES dealer, who will test the product and if necessary, forward it to NILES for service. If there are no authorized NILES dealers in your area, you must write to NILES and include your name, model and serial number of your unit, along with a brief description of the problem. A factory Return Authorization Number will be sent to you. **DO NOT RETURN ANY UNIT WITHOUT FIRST RECEIVING WRITTEN AUTHORIZATION AND SHIPPING INSTRUCTIONS FROM NILES.**

If the above conditions are met, the purchaser's sole remedy shall be to return the product to NILES, in which case NILES will repair or replace, at its sole option, the defective product without charge for parts or labor. NILES will return a unit repaired or replaced under warranty by shipping same by its usual shipping method from the factory (only) at its expense within the United States of America. **THERE ARE NO OTHER WARRANTIES, INCLUDING WITHOUT LIMITATION, EITHER EXPRESS OR IMPLIED WARRANTIES OF MERCHANTABILITY OR FITNESS FOR A PARTICULAR PURPOSE, WITH RESPECT TO THE PRODUCT.**

**REPAIR OR REPLACEMENT AS PROVIDED UNDER THIS WARRANTY IS THE EXCLUSIVE REMEDY OF THE CONSUMER/PURCHASER. NILES SHALL NOT BE RESPONSIBLE FOR ANY INCIDENTAL OR CONSEQUENTIAL DAMAGES EXCEPT TO THE EXTENT PROVIDED (OR PROHIBITED) BY APPLICABLE LAW.**

Some states do not allow the exclusion or limitation of incidental or consequential damages, so the above limitation may not apply to you. This warranty gives you specific legal rights, and you may also have other rights which vary from state to state.

For the name of your nearest authorized NILES dealer contact:

### **NILES AUDIO CORPORATION**

P.O. BOX 160818, Miami, Florida 33116-0818.  
1-800-BUY-HIFI (800-289-4434)

Please fill in your product information and retain for your records.

**Model** \_\_\_\_\_

**Serial No.** \_\_\_\_\_

**Purchase Date** \_\_\_\_\_



**NILES®**

**Niles Audio Corporation**

**12331 S.W. 130 Street**

**Miami, Florida 33186**

**Tel: (305) 238-4373**

**Fax: (305) 238-0185**

Printed in China

©2004 Niles Audio Corporation. All rights reserved. Niles reserves the right to change product specifications without notice. Niles, the Niles logo and Blending High Fidelity and Architecture are registered trademarks of Niles Audio Corporation. MicroPerf and UltraSilk is a trademark of Niles Audio Corporation. Printed in China. 11/04 DS00427ACN